

MODEL NO.:  
**PJR-D32670-A BK7 ASB2 L-RH**  
 (1) (2) (3) (4) (5) (6)

(1) Series no.  
 (2) Schematic type: A  
 (3) Housing material and color:  
 BK7=PA10T(black)  
 (4) Terminal plating:  
 ASB2=1#~4#Gold flash on contact  
 area, 80u" Matte tin on  
 solder tail;5#,#6# Silver plating.  
 50-100u" Black nickel on  
 contact area

(5) Packing mode:L=Reel packing  
 (6) Environmental requirements:  
 ROHS COMPLIANT & Halogen Free

1.Electrical characteristics  
 1.1.Current rating:DC 0.5A max.  
 1.2.Voltage rating:DC 30V.  
 1.3.Contact resistance: ≤50mΩ(Initial)  
 After test: ≤100mΩ  
 1.4.Insulation resistance:  
 100MΩ min. at 500V DC.  
 1.5.Withstanding voltage:  
 500V AC for 1 minute.  
 2.Mechanical characteristics  
 2.1.Life test:5000 cycles min,  
 2.2.Mating force:4~30N,  
 Unmating force:4~30N.  
 3.Temperature range: -40°C~+80°C

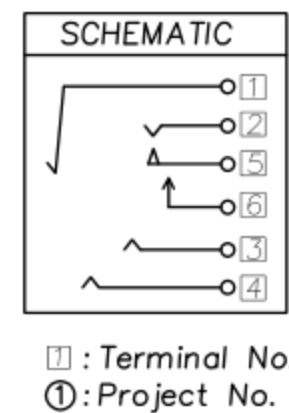

NO.	DESCRIPTION	QTY	MATERIAL	REMARK
⑧	Make terminal	⑥	1 C5210, 0.20t	5u" Silver, 50u" Ni underplated.
⑦	Transfer Spring	⑤	1 C5210, 0.20t	
⑥	Ring spring	④	1 C5210, 0.20t	
⑤	Ring spring	③	1 C5210, 0.20t	
④	Tip spring	②	1 C5210, 0.20t	Gold Flash on contact area, 80u" Matte tin on solder tail, 50u" Ni underplated.
③	Earth spring	①	1 C5210, 0.20t	
②	Separator	1	PA10T UL-94V0	Black
①	Housing	1		Black

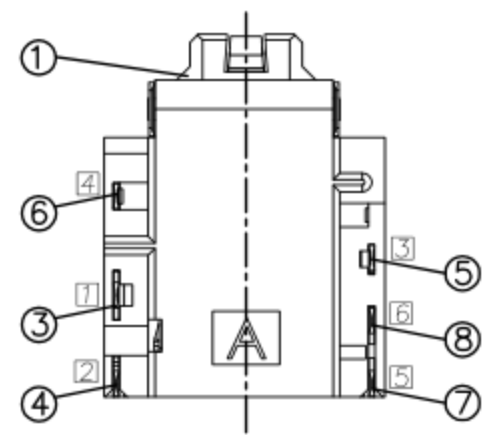
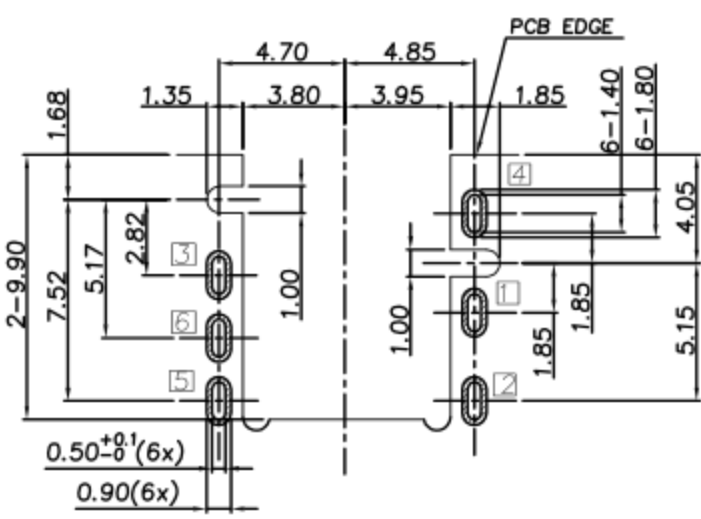
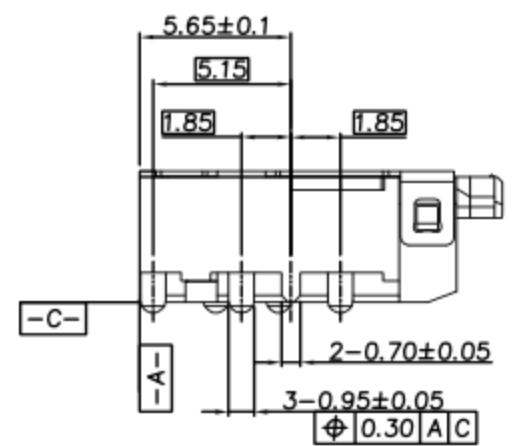
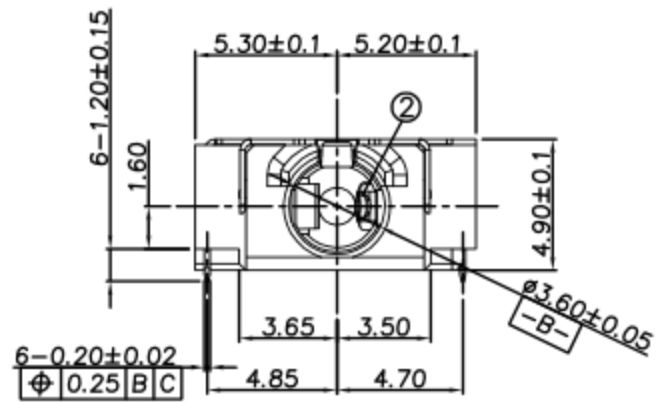
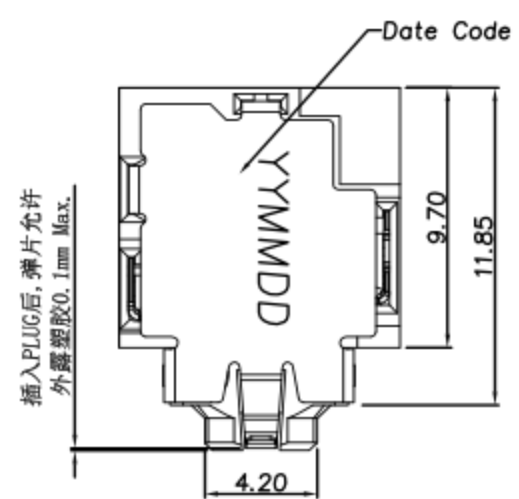
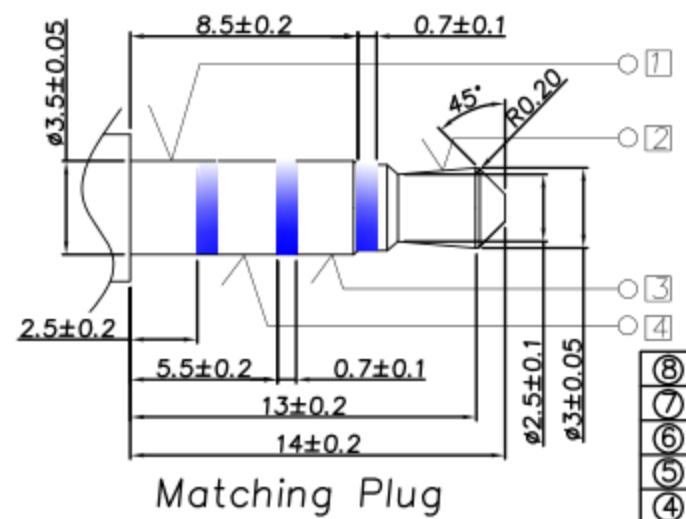

ECN NO.	REV	DATE	DESCRIPTION	CHANGE	APPRO.	GENERAL TOLERANCE UNLESS OTHERWISE NOTED	DESIGN	CHECK	APPROVAL	SCALE: 3:1	UNIT:mm	A4	SHEET: 1 of 1
	A-2	2017.07.21	修改弹片外露标准	Andy	刘伟	X.X ±0.35							
	A-1	2017.07.11	按客户要求, 修改尺寸标注	Andy	刘伟	X.XX ±0.25							
	A-0	2015.11.12	NEW	YUPUN	余军	X.XXX ±0.15							
						ANGEL ±3°							

<b>东莞市高迪电子有限公司</b>	
TITLE:	φ3.5mm PHONE JACK
MODEL NO.	PJR-D32670-ABK7ASB2L-RH
FILE NO.	Q/DY.QW-001A-0566